

SPAN™ Liquid Filled Industrial Gauge – 2.5"

Overview

Span gauges are designed for rugged service applications. Liquid fill fluid dampens the gauge pointer movement for improved readings and longer life, making these gauges ideal for high shock and vibration applications.

Its Zytel case and ring offer good appearance and excellent resistance to chemical, weather, and corrosion attack.

The Span gauge has many optional features that allow a user to develop a basic or special product specification.

Benefits

- “Fully Filled”: The internal “breathing diaphragm” eliminates the need for an air bubble in the mid-range of the gauge, which can distort readings and looks unsightly. The ICD is standard up to 60 PSI, optional on higher ranges.
- Temperature compensated: The ICD compensates the case (to 150F) for changes in internal case pressure caused by fluctuations in ambient temperature. (Especially critical in lower pressure and vacuum gauges.)

Options

- Freeze Proof: The KEM-X Socket Saver is an internal diaphragm seal to prevent freezing, clogging, and corrosion. It is available on all SPAN gauges.
- Lighted Dial: Span offers the only lighted and liquid filled gauge. 12 or 24 volt incandescent and LED in white, blue, green, or red.

Applications

- Mobile Hydraulic Equipment
- Fire Apparatus
- Water Purification/Irrigation
- Bulk Transport Trailers
- Waste Water/Slurry
- Military, Marine



LFC-224 Span 2.5" Liquid Filled Industrial Gauge

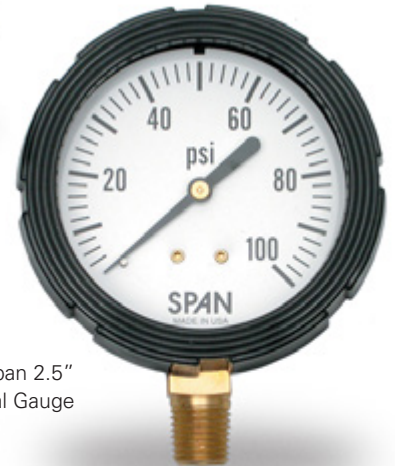

LFS-220 Span 2.5" Liquid Filled Industrial Gauge

Construction Data

Case	Zytel Nylon – Black
Bezel	Zytel Nylon – Removable
Socket	Brass
Socket O Ring	EPDM
Bourdon Tubes	Vac to 1000 PSI Copper Alloy “C” Tube 1500 to 7500 Stainless Spiral Tube
Pressure Connection	¼” NPT Male (JIC Optional)
Lens	Acrylic
Pointer	Black Aluminum
Movement	Precision Swiss Movement
Dial	White Aluminum
Fill fluid	High Purity Glycerin
Ranges	Vacuum, Compound to 7500 PSI

Dial Ranges and Intervals

Standard Dial Range	Numbered	Minor	Standard Dial Range	Numbered	Minor
30" Hg	5"	.5"	0-200	20	2
30-0-15	10"-3 psi	2"-1 psi	0-300	50	5
30-0-30	10"-5 psi	2"-1 psi	0-400	50	5
30-0-60	30"-10 psi	5"-2 psi	0-600	100	10
30-0-150	30"-25 psi	10"-5 psi	0-1000	100	10
30-0-300	30"-50 psi	15"-10 psi	0-1500	300	20
30-0-600	30"-100 psi	30"-20 psi	0-2000	200	20
0-15	3	.2	0-3000	500	50
0-30	5	.5	0-5000	500	50
0-60	10	1	0-6000	1000	100
0-100	10	1	0-7500	1500	100
0-160	20	2			

Thuemling Instrument Group

1225 Pearl Street, Waukesha, WI 53186 • Phone: 262-547-1789 • Toll Free: 1-800-686-1789
 Fax: 262-547-6493 • Web: www.thuemling.com • Email: thuemling@earthlink.net



SPAN™ Liquid Filled Industrial Gauge – 2.5"

Performance Data

Accuracy	3-2-3% Grade B 1% Grade 1A (Optional)
Design	ANSI/ASME B40.1
Operating Temp.	-40 to 150F

Temperature Error

Additional error when temperature changes from reference temperature of 68F (20C) +0.4% for every 18F (10C) rising or falling as a percentage of Span.

Weather Protection

Weather tight (NEMA 4X / IP 65)

Optional Extras

ICD	=	Internal Temperature Compensating Diaphragm
IPG	=	Lighted Dial
IB	=	KEMX Buna-N - Diaphragm
IV	=	KEMX Viton - Diaphragm
IE	=	KEMX EPDM - Diaphragm
SCK	=	Threaded Socket Restrictor
CERT	=	NIST Certified with Calibration Points
SFB	=	Chrome Bezel
RECAL	=	Slotted Adjustable Pointer
O2C	=	Oxygen Cleaning
GL	=	Glass Lens
STUD	=	Back Mount Studs for Wall Mounting
DM	=	Dampened Movement
OEM	=	Custom Dials
JIC	=	#4 JIC Process Connection
Duel Scale	=	Call for Availability

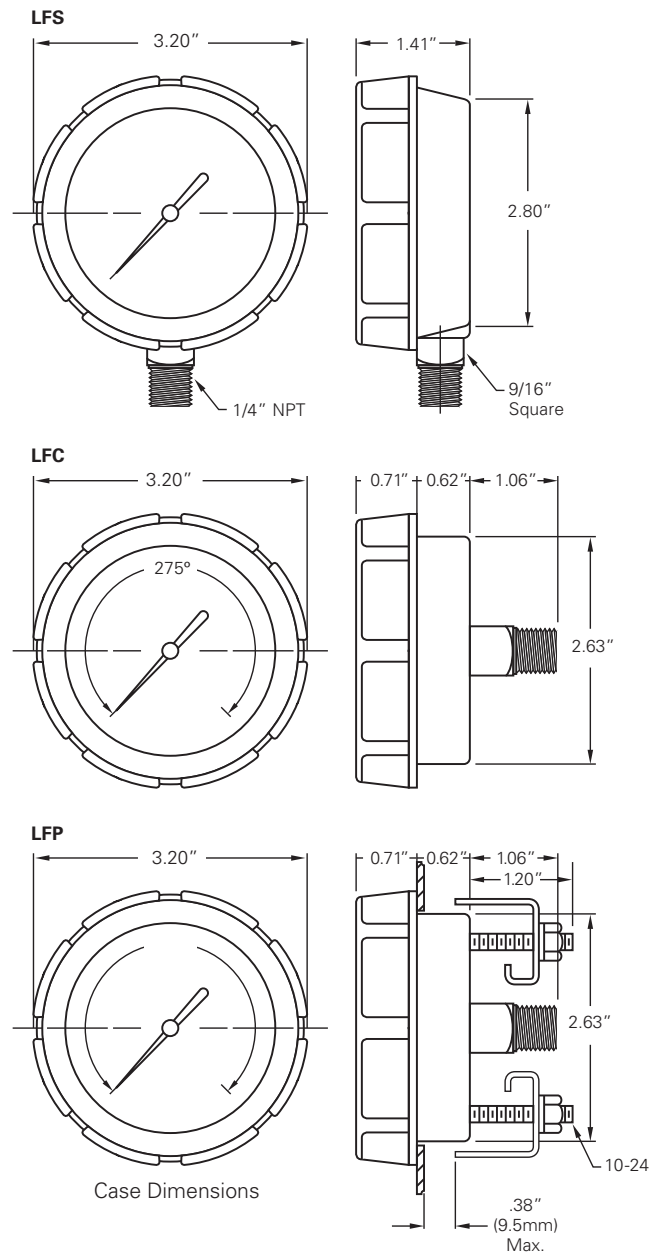

Case Dimensions

Ordering Number for 2.5" Span Gauge – Construct by selecting one item from each of the columns below:

Configuration	Dial Size	Accuracy	Wetted Parts	Range	Fill	Options
LFS = Stem Mount Bottom	2 = 2-1/2	2 = 3 - 2 - 3% Accuracy	0 = Phosper Bronze Tube, Brass Socket	Please Specify from Chart	G = Glycerin Filled	From Option List
LFC = Center Back Mount		1 = 1% Accuracy (Optional)	4 = 1500 PSI and Above: 316L tube, Brass Socket		D = Dry No fill	
LFP = Panel Mount U-Clamp						
Example: LFS -	2	2	0 -	100 -	G	IB

(LFS-220-100-G - IB)

Thuemling Instrument Group

1225 Pearl Street, Waukesha, WI 53186 • Phone: 262-547-1789 • Toll Free: 1-800-686-1789
 Fax: 262-547-6493 • Web: www.thuemling.com • Email: thuemling@earthlink.net

